



BLIND NUT & STUD RIVETING KIT

MODEL NO: **AK396.V4**

Thank you for purchasing a Sealey product. Manufactured to a high standard, this product will, if used according to these instructions, and properly maintained, give you years of trouble free performance.

IMPORTANT: PLEASE READ THESE INSTRUCTIONS CAREFULLY. NOTE THE SAFE OPERATIONAL REQUIREMENTS, WARNINGS & CAUTIONS. USE THE PRODUCT CORRECTLY AND WITH CARE FOR THE PURPOSE FOR WHICH IT IS INTENDED. FAILURE TO DO SO MAY CAUSE DAMAGE AND/OR PERSONAL INJURY AND WILL INVALIDATE THE WARRANTY. KEEP THESE INSTRUCTIONS SAFE FOR FUTURE USE.



Refer to instructions



Wear eye protection

1. SAFETY

- ❑ **WARNING!** Ensure Health & Safety, local authority and general workshop practice regulations are adhered to when using this equipment.
- ✓ Familiarise yourself with the application and the limitations of the riveter, as well as the potential hazards.
- ✓ Maintain the riveter in good condition (use an authorised service agent).
- ✓ Replace or repair damaged parts. Use genuine parts only. Unauthorised parts may be dangerous and will invalidate the warranty.
- ✓ Keep the work area clean, uncluttered and ensure there is adequate lighting.
- ✓ Keep the riveter clean for best and safest performance.
- ✓ Check moving parts alignment on a regular basis.
- ✗ **DO NOT** hold the workpiece by hand. Secure unstable workpiece with a clamp, vice or other adequate holding device.
- ✓ Ensure the workpiece is correctly secured before using the riveter.
- ✗ **DO NOT** use the riveter for any purpose other than that it was designed for.
- ✗ **DO NOT** operate the riveter if any parts are damaged or missing, as this may cause failure and/or personal injury.
- ✓ When not in use store in a safe, dry, childproof location.

2. INTRODUCTION

Suitable for blind rivets, rivet nuts and rivet studs in aluminium, steel and stainless steel. 360° Swivel head gives greatly improved accessibility. Four nozzles for blind rivets, four mandrels for rivet nuts and three mandrels for rivet studs. Supplied with spanners and a selection of steel rivet nuts.

3. SPECIFICATION

Model no.:AK396.V4

Contents:

Blind Rivet Nozzle Sizes:

2.4(3/32"), 3.2(1/8"), 4(5/32"), 4.8mm(3/16")

Rivet Nut Sizes: M3 x 0.5, M4 x 0.7, M5 x 0.8, M6 x 1mm

Rivet Stud Sizes: M4 x 0.7, M5 x 0.8, M6 x 1mm

Rivet Materials:

Aluminium, Steel, Stainless Steel

Rivets Nuts Supplied: M3 x 0.5, M4 x 0.7, M5 x 0.8, M6 x 1mm (10pc each)

4. CONTENTS

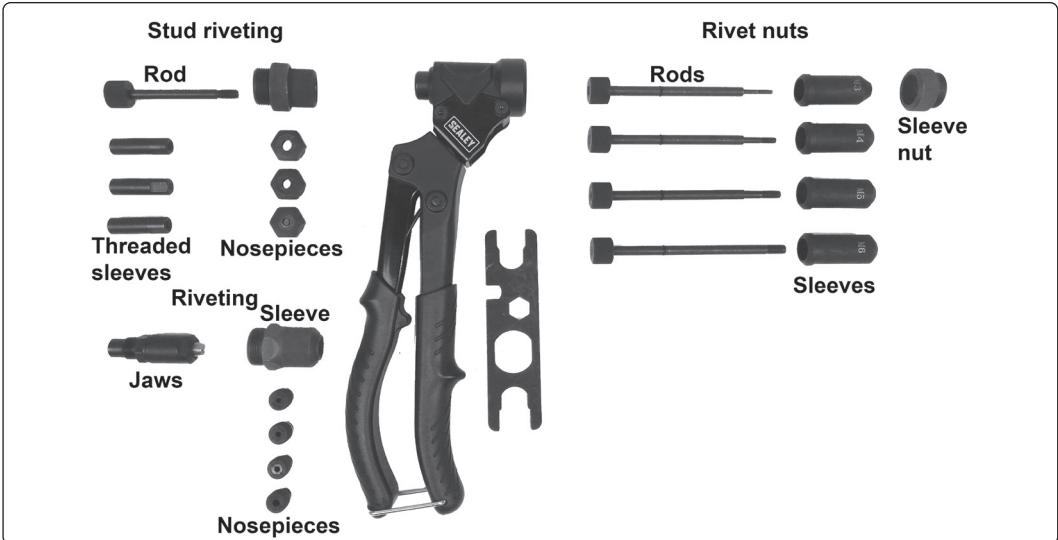

5. SET UP

Numbers refer to attached Parts List

5.1. RIVETING (fig.1)

5.1.1. Screw jaws and sleeve into body, select appropriate size of nosepiece to match rivet.

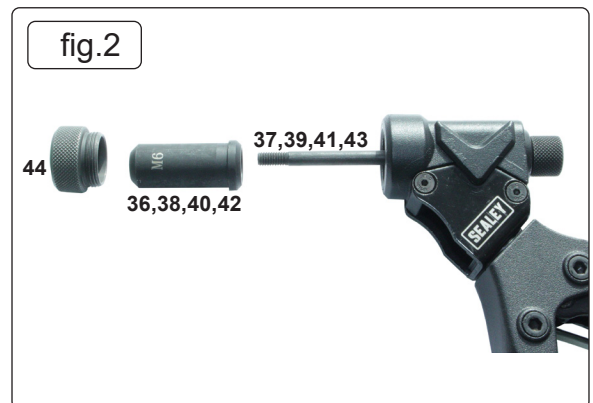
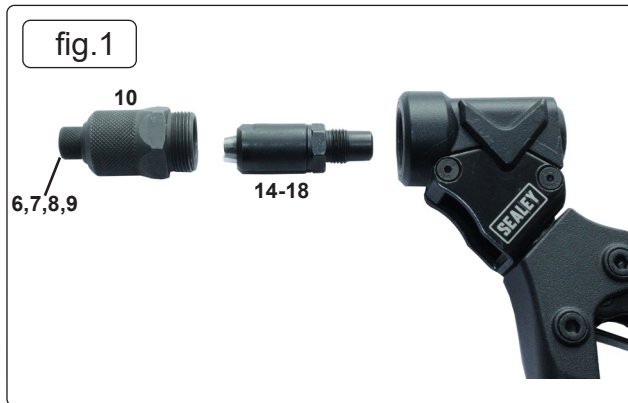

5.2. RIVET NUT (fig.2) (fig.2.A for operation)

5.2.1. Push appropriate size of rivet nut rod (M3 - M6) into back of body.

5.2.2. Slide sleeve over pull rod and fit sleeve nut.

5.2.3. Note left-hand thread.

5.2.4. OPERATION

NOTE: Always use sleeve and rod of the same size, determined by the size of nut rivet.

5.2.4.1. Prepare a sample of the workpiece material with a hole slightly larger than the nut rivet diameter.

5.2.4.2. Screw the nut rivet fully onto the rod.

5.2.4.3. Place the nut rivet in the hole in the sample and press down so that the nut flange is held firmly against the face of the sample.

5.2.4.4. Squeeze the riveter handles to compress the nut rivet.

5.2.4.5. The rivet will form a retaining bulge against the rear face of the sample.

5.2.4.6. Unscrew the rod from the rivet nut rivet by turning the knurled end of the draw bar body.

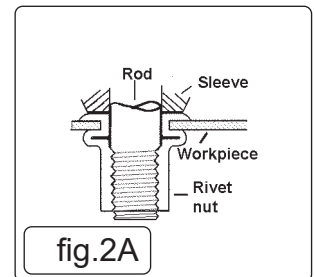

5.3. RIVET STUD (fig.3)

5.3.1. Push turnable bar (35) into back of body.

5.3.2. Screw riveting rod (32/33/34) onto turnable bar (35). **Note:** reverse thread.

5.3.3. Screw fixing nut sleeve and adjusting nut (45 & 49) onto body.

5.3.4. Screw nut guide (46/47/48) onto fixing sleeve and adjusting nut assembly (45 & 49).

5.3.5. OPERATION

5.3.5.1. Follow same procedure for Rivet nut Operation above.

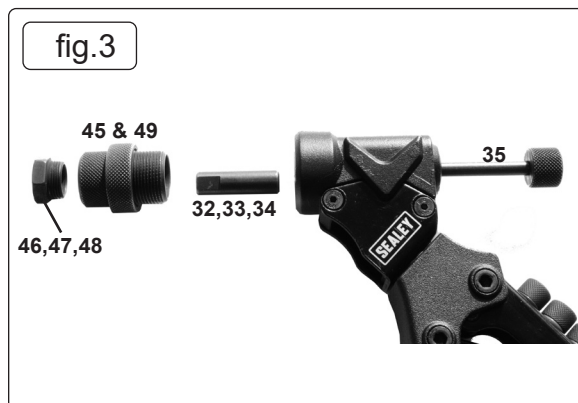

ENVIRONMENT PROTECTION

Recycle unwanted materials instead of disposing of them as waste. All tools, accessories and packaging should be sorted, taken to a recycling centre and disposed of in a manner which is compatible with the environment. When the product becomes completely unserviceable and requires disposal, drain any fluids (if applicable) into approved containers and dispose of the product and fluids according to local regulations.

Note: It is our policy to continually improve products and as such we reserve the right to alter data, specifications and component parts without prior notice. Please note that other versions of this product are available. If you require documentation for alternative versions, please email or call our technical team on technical@sealey.co.uk or 01284 757505.

Important: No Liability is accepted for incorrect use of this product.

Warranty: Guarantee is 12 months from purchase date, proof of which is required for any claim.

Sealey Group, Kempson Way, Suffolk Business Park, Bury St Edmunds, Suffolk. IP32 7AR



01284 757500



01284 703534



sales@sealey.co.uk



www.sealey.co.uk